



PRODUCT DATA & INSTALLATION

Bulletin KJBF-PDI-12

1064046

We are on the Internet



www.keepriterefrigeration.com

JBF Hot Gas and Electric Defrost Blast Freezers 60Hz

Medium and Low Temperature Applications -40 °F (-40°C) and Higher

Electrical Power: 208-230/3/60, 460/3/60, 575/3/60

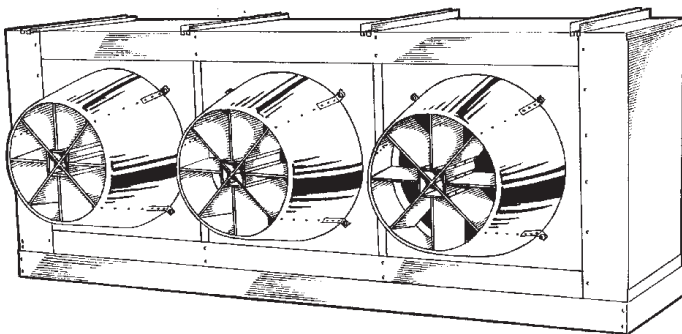

- Incoloy defrost heaters mounted in slots on both sides of cooling coils. (electric defrost models only)
- Drain pans on stainless steel hinges for easy access. (electric models only)
- Factory installed fan delay and defrost termination thermostat.
- Rugged high efficiency cast aluminum air foil fans.
- Hinged side panels allow easy access for refrigeration circuit and electrical compartment.
- Schrader fitting and external equalizer line.
- Plug-in motors with moulded lead and connector.
- Unit is shipped upright for convenient handling and quick installation.
- Corrosion resistant, easy to clean vinyl coated fan guards.
- Electrical terminals with recessed connections for dependable operation.

NOMENCLATURE

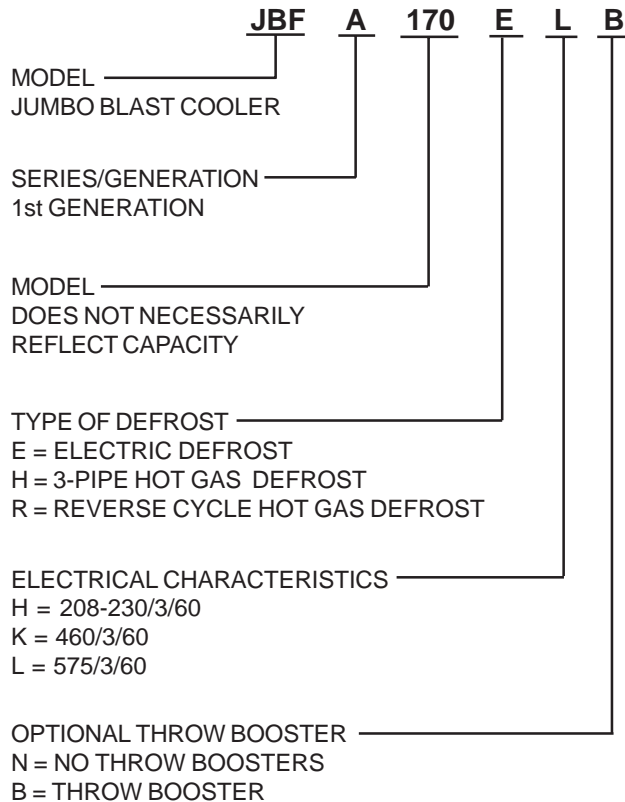

CONTENTS

PAGE

Nomenclature.....	Cover
60Hz Capacity Data.....	2
Air Flow Data.....	2
Correction Factors.....	2
60Hz Fan Motor Electrical Data.....	3
60Hz Defrost Heater Electrical Data..	3
Refrigerant Charge.....	3
Refrigerant Piping Schematics.....	3
Wiring Diagram-Hot Gas Defrost.....	4
Wiring Diagram-Electric Defrost.....	5
Dimensions & Weights	
Electric Defrost Model.....	6
Dimensions and Weights	
Hot Gas Defrost Models.....	7, 8
Installation Instructions.....	8, 9, 10
Service Parts List.....	11
Project Information.....	Back

SPECIFICATIONS

CAPACITY DATA

Model	Fin Spacing FPI	No. of Fans	Capacity* at 0" W.C. E.S.P.	Capacity* at 0.25" W.C. E.S.P.	Capacity* at 0.5" W.C. E.S.P.	Capacity* at 0.75" W.C. E.S.P.	Capacity* with Booster
JBFA075	6	2	74.91	71.57	69.73	66.58	66.40
JBFA090	6	2	91.23	88.22	84.79	80.81	80.26
JBFA105	6	2	104.03	100.52	96.42	91.71	92.91
JBFA120	6	2	113.55	109.62	104.98	99.67	101.76
JBFA130	6	3	127.41	122.98	118.23	112.38	113.73
JBFA150	6	3	145.25	140.02	135.02	127.41	130.10
JBFA170	6	3	158.51	152.54	147.13	138.29	142.43
JBFA 069	5	2	68.82	66.58	64.13	61.26	60.95
JBFA 084	5	2	84.76	81.94	78.80	75.18	75.33
JBFA 099	5	2	97.60	94.32	90.52	86.24	87.01
JBFA 114	5	2	110.71	106.96	102.48	97.44	99.03
JBFA 122	5	3	118.11	114.14	109.76	104.44	105.31
JBFA 142	5	3	136.14	131.36	126.08	119.33	121.78
JBFA 163	5	3	150.27	144.75	138.68	131.45	134.78
JBFA 063	4	2	61.59	63.76	57.42	54.92	54.50
JBFA 078	4	2	76.46	73.92	71.18	67.94	67.83
JBFA 092	4	2	89.30	86.32	82.95	79.07	79.11
JBFA 108	4	2	99.65	96.32	92.43	87.95	88.95
JBFA 111	4	3	107.17	103.53	99.64	94.91	95.33
JBFA 132	4	3	124.76	120.48	115.76	110.04	111.32
JBFA 153	4	3	139.29	134.31	128.78	122.27	124.68

SATURATED EVAP TEMP	CORRECTION FACTOR
20°F (-6.7°C)	1.00
10°F (-12.2°C)	.98
-0°F (-17.8°C)	.95
-10°F (-23.3°C)	.91
-20°F (-28.9°C)	.85
-30°F (-34.4°C)	.79
-40°F (40 °C)	.72

* No allowance made for fan heat - add 3,410 BTUH (1,000 watt) per HP to room load for motor heat.
Evaporators rated at 20°F S.S.T. & 10°F TD

AIR FLOW DATA

MODEL	CFM at 0" W.C. E.S.P.	Throw Ft.	CFM at 0.25" W.C. E.S.P.	Throw Ft.	CFM at 0.5" W.C. E.S.P.	Throw Ft.	CFM at 0.75" W.C. E.S.P.	Throw Ft.	CFM with Booster	Throw Ft.
JBFA075	25300	72	23380	67	22320	64	20500	58	20400	133
JBFA090	24500	70	23140	66	21580	62	19780	56	19800	129
JBFA105	23760	68	22420	64	20860	59	19060	54	19520	127
JBFA120	23060	66	21740	62	20180	58	18400	52	19100	124
JBFA130	35580	68	33510	64	31290	60	28560	54	29190	126
JBFA150	34290	65	32250	61	30300	58	27330	52	28380	123
JBFA170	33090	63	31050	59	28800	55	26190	50	27600	120
JBFA069	25540	73	24120	69	22560	64	20740	59	20540	134
JBFA084	24820	70	23420	67	21860	62	20060	57	20140	131
JBFA099	24140	69	22780	65	21200	60	19420	55	19740	128
JBFA114	23480	67	22160	63	20580	59	18800	54	19360	126
JBFA122	36090	87	34050	65	31800	60	29070	56	29520	128
JBFA142	34920	66	32880	63	30630	58	27760	53	28800	125
JBFA163	33810	64	31770	60	29520	56	26850	51	28080	122
JBFA063	25780	73	27340	78	22780	65	20980	60	20680	134
JBFA078	25140	72	23720	68	22180	63	20360	58	20300	132
JBFA092	24520	70	23140	66	21580	62	19780	56	19800	129
JBFA108	23900	68	22500	64	21000	60	19200	55	19600	127
JBFA111	36690	70	34590	66	32340	61	29610	56	29850	129
JBFA132	35580	68	33540	64	31290	60	28560	54	29170	126
JBFA153	34560	66	35520	62	30240	58	27570	52	28560	124

W.C. = Water Column
E.S.P. = External Static Pressure

FAN MOTOR ELECTRICAL DATA

			H 208-230/3/60			K 460/3/60			L 575/3/60		
Model JBFA	Fan Motor Qty/HP	Type of Motor	Total F.L.A.	M.C.A.	M.O.P.	Total F.L.A.	M.C.A.	M.O.P.	Total F.L.A.	M.C.A.	M.O.P.
063 069 075 078 084 090 092 099 105 108 114 120	2/3	Standard TEFC	17.2/16.8	19.4	25	8.4	9.5	15	7.0	7.9	15
111 122 130 132 142 150 153 163 170	3/3	Standard TEFC	25.8/25.2	28.0	35	12.6	13.7	20	10.5	11.4	15

DEFROST HEATER ELECTRICAL DATA

			H 208-230/3/60			K 460/3/60			L 575/3/60		
Model JBFA	Fan Motor No.	Total heater kW	Total Amperes	M.C.A.	M.O.P.	Total Amperes	M.C.A.	M.O.P.	Total Amperes	M.C.A.	M.O.P.
063 069 075	2	14.0	38.1/42.2	40/48	50/60	21.1	24	30	16.9	20	25
078 084 090	2	19.6	48/53.1	48/56	60/70	26.5	28	35	21.2	24	30
092 099 105	2	22.4	57.2/63.3	64/64	80/80	31.6	32	40	25.3	28	35
108 114 120	2	22.4	57.2/63.3	64/64	80/80	31.6	32	40	25.3	28	35
111 122 130	3	22.4	57.2/63.3	64/64	80/80	31.6	32	40	25.3	28	35
132 142 150	3	25.2	57.2/63.3	64/64	80/80	31.6	32	40	25.3	28	35
153 163 170	3	28.0	67/74.1	72/80	90/100	37.0	40	50	29.6	32	40

† Amperage draw on phase with maximum load. (Operating current only)

* Electrical wiring is to be sized in accordance with minimum ampacity rating.

M.C.A. = Minimum Circuit Ampacity • M.O.P. = Maximum Overcurrent Protection

REFRIGERANT CHARGE

MODEL JBFA			R-22		R-404A		R-502	
			lb	kg	lb	kg	lb	kg
063	069	075	34.2	15.5	32.9	15.0	37.6	17.1
078	084	090	45.6	20.7	43.9	19.9	50.1	22.8
092	099	105	57.0	25.9	54.8	24.9	62.7	28.5
108	114	120	68.4	31.1	65.8	29.9	75.2	34.2
111	122	130	60.8	27.6	58.5	26.6	66.9	30.4
132	142	150	76.0	34.5	73.1	33.2	83.6	38.0
153	163	170	91.2	41.5	87.7	39.9	100.3	45.6

Refrigerant charge with 30% full coil @ 20 °F S.S.T. (R-22), -20 °F S.S.T. (R-404A, R-502)

REFRIGERANT PIPING SCHEMATICS

REVERSE CYCLE DEFROST SYSTEM

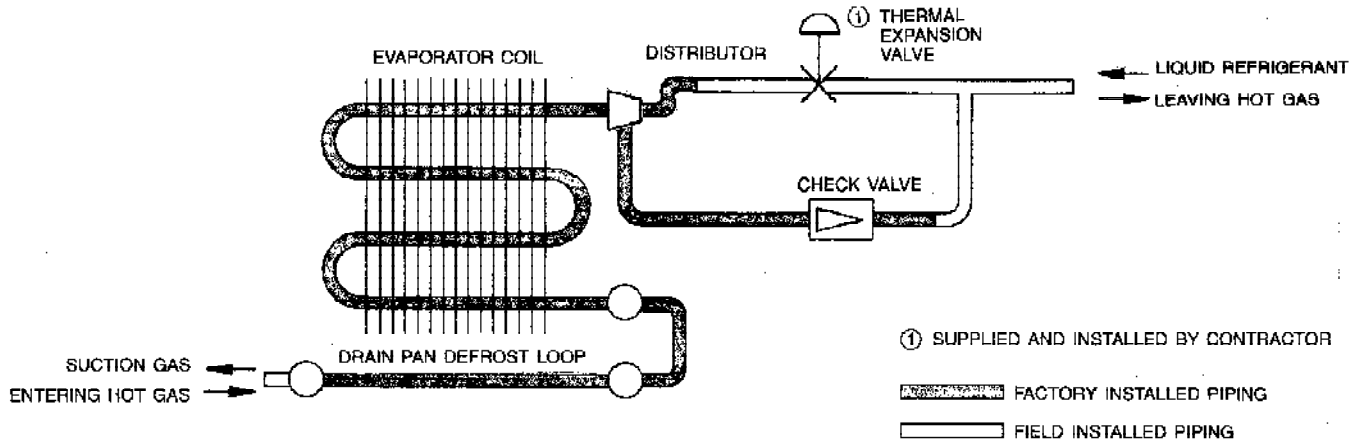

3 - PIPE DEFROST SYSTEM

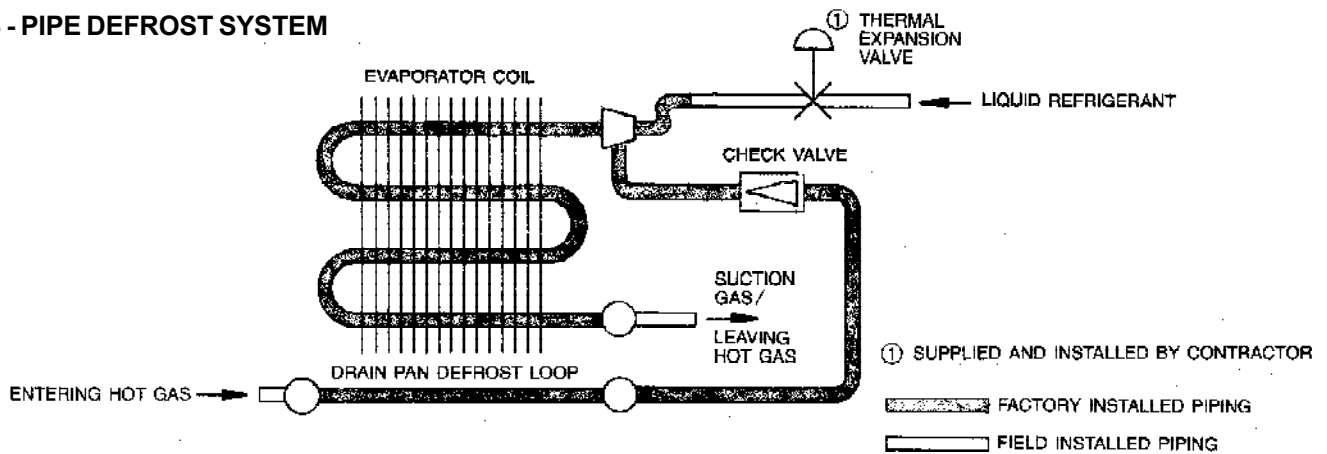

WIRING DIAGRAM - JBF HOT GAS DEFROST

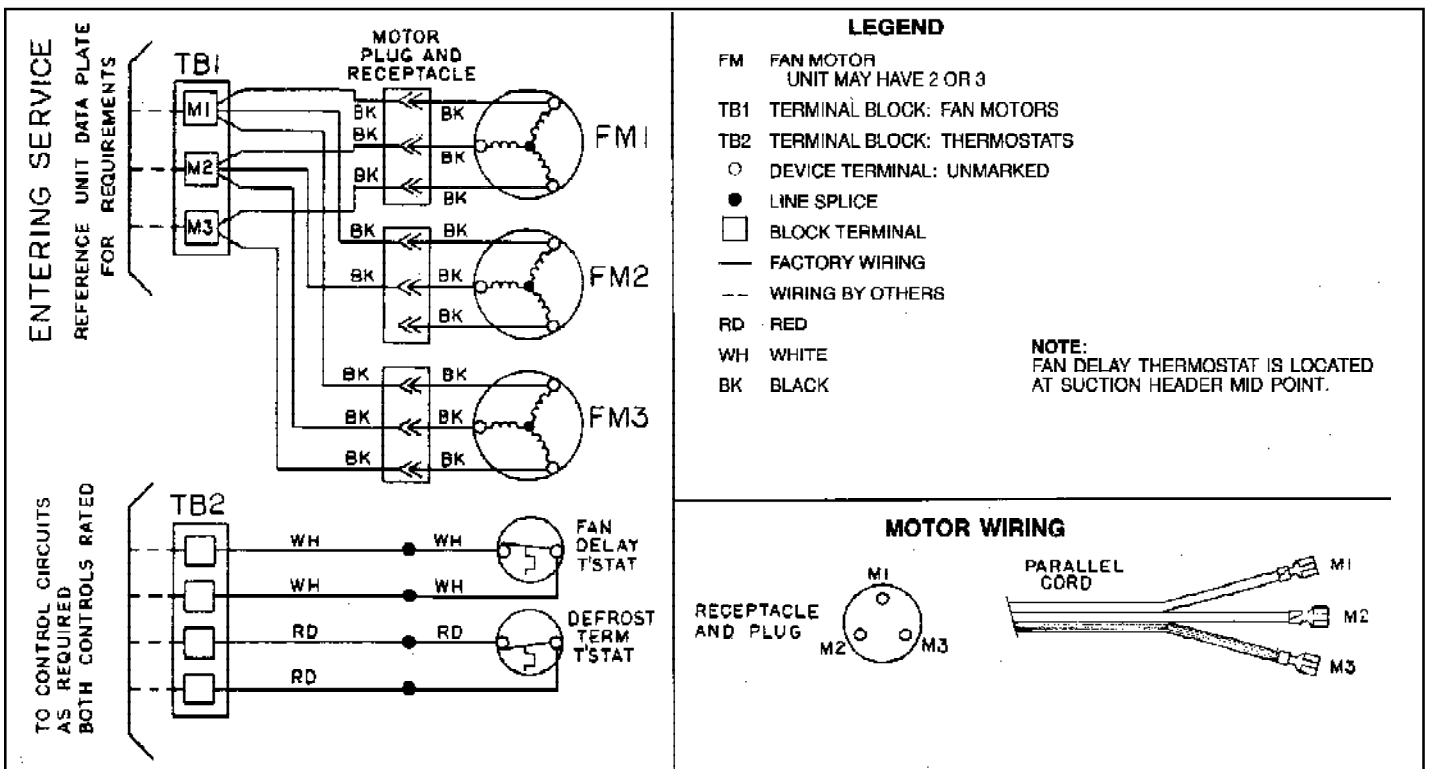

WIRING DIAGRAM - JBF ELECTRIC DEFROST

ENTERING SERVICE SEE DATA PLATE FOR REQUIREMENT

SYSTEM WIRING DIAGRAM

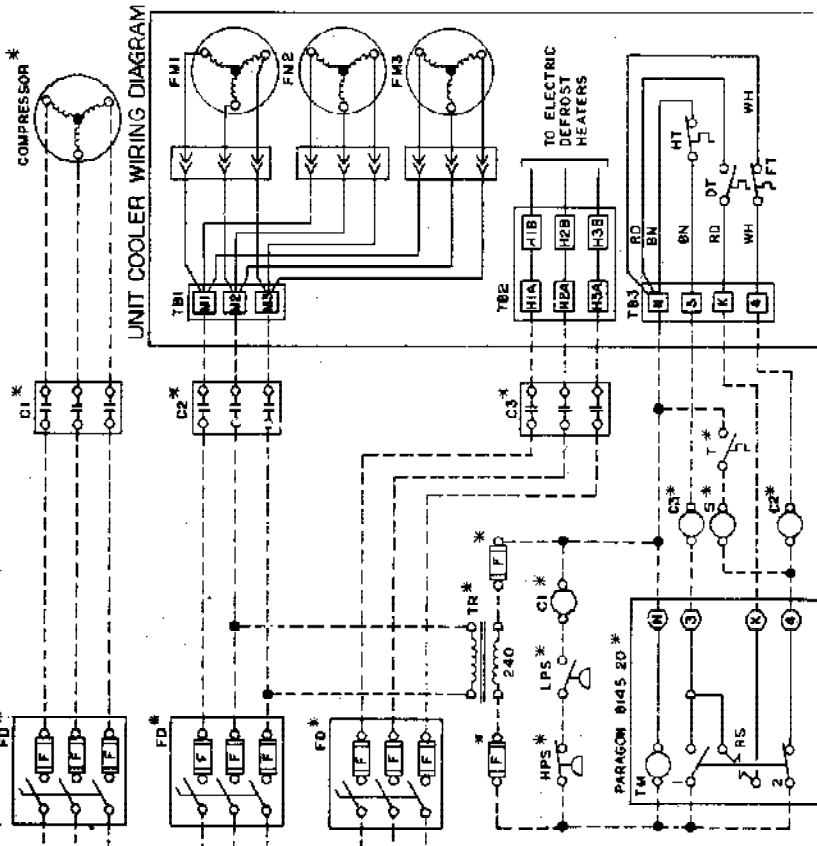

COMPONENT TERMINAL IDENTIFICATION DIAGRAM

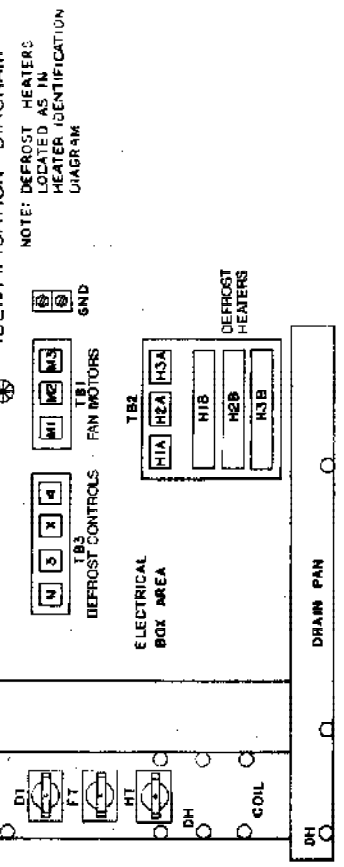

DEFROST HEATER CONNECTION DIAGRAMS

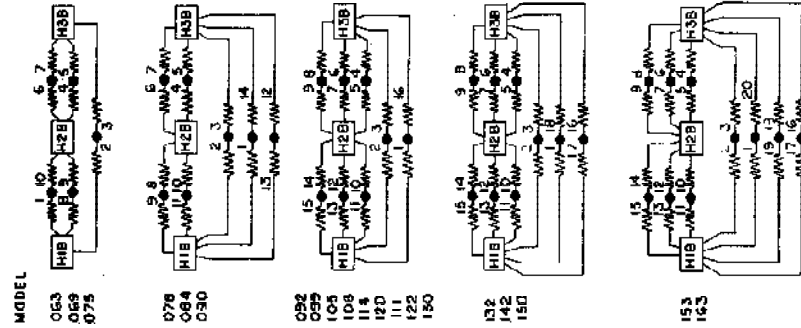

MOTOR WIRING

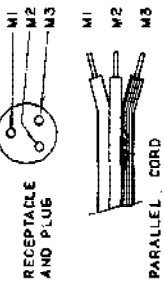

LEGEND

SYMBOL	DESCRIPTION
C	CONTACTOR
DH	DEFROST HEATER
DT	DEFROST TERMINATION THERMOSTAT
F	FUSE
FD	FUSED DISCONNECT
FM	FAN MOTOR
HPS	HIGH PRESSURE SWITCH
LPS	LOW PRESSURE SWITCH
S	SOLENOID
T	ROOM THERMOSTAT
TB	TERMINAL BLOCK
TR	TRANSFORMER
TM	TIMER MOTOR
RS	RELEASE SOLENOID
○	DEVICE TERMINAL UNMARKED
●	DEVICE TERMINAL MARKED
—	LINE SPLICE
□	BLOCK TERMINAL
*	COMPONENTS BY OTHERS
—	FACTORY WIRING
- - -	WIRING BY OTHERS
HT	HEATER THERMOSTAT
FT	FAN DELAY THERMOSTAT

HEATER IDENTIFICATION DIAGRAM

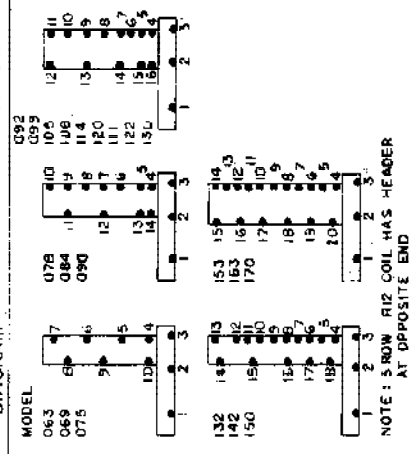

ELECTRICAL DEFROST DIMENSIONS AND WEIGHTS

Electrical Service Entrance Knockouts		
	2 Fan Models	3 Fan Models
Motors - D	7/8" (22) Dia.	7/8" & 1-3/32" (22) & (28) Dia.
Controls - E	7/8" (22) Dia.	7/8" (22) Dia.
Heaters - F	1-3/32", 1-23/64" & 1-23/32" (28), (35) & (44) Dia.	1 3/32", 1 23/64" & 1 23/32" (28), (35) & (44) Dia.

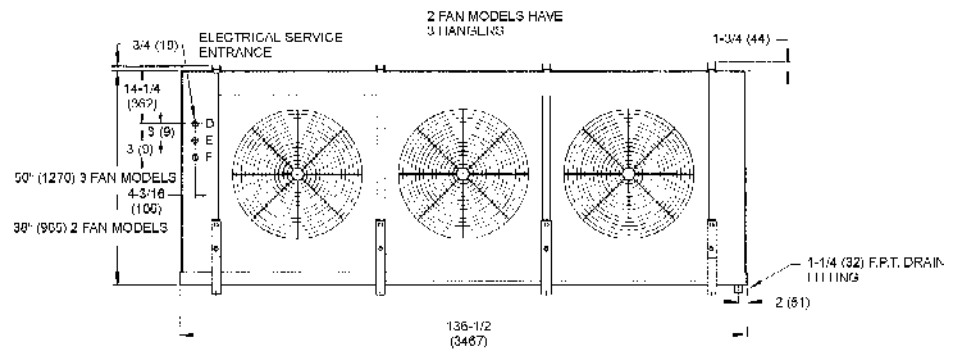
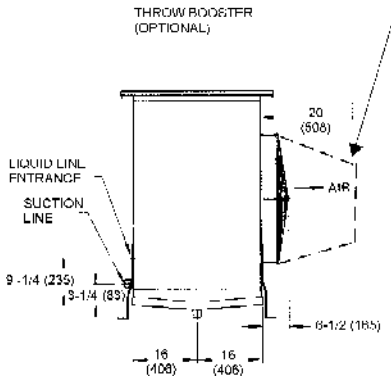
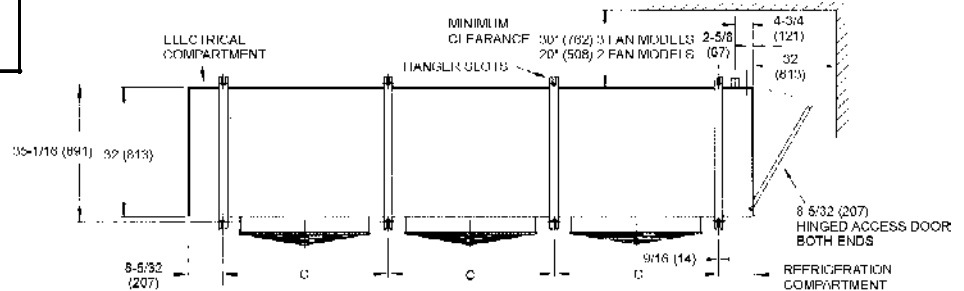

All Dimensions (mm)

ELECTRIC DEFROST MODEL	HEIGHT		HANGERS		REFRIGERANT CONNECTIONS (1)		UNIT WEIGHT	
	Inches	mm	C		LIQUID	SUCTION	Lb.	kg
			Inches	mm	R404A,R-22,R-502	R404A,R-22,R-502		
JBFA 075E	38	965	60 1/16	1526	1 3/8	2 1/8	830	376
JBFA 090E	38	965	60 1/16	1526	1 3/8	2 1/8	900	408
JBFA 105E	38	965	60 1/16	1526	1 3/8	2 1/8	1000	454
JBFA 120E	38	965	60 1/16	1526	1 3/8	2 1/8	1100	499
JBFA 130E	50	1270	40 1/16	1018	1 3/8	2 1/8	1225	556
JBFA 150E	50	1270	40 1/16	1018	1 3/8	2 1/8	1305	592
JBFA 170E	50	1270	40 1/16	1018	1 3/8	2 1/8	1390	631
JBFA 069E	38	965	60 1/16	1526	1 3/8	2 1/8	830	376
JBFA 084E	38	965	60 1/16	1526	1 3/8	2 1/8	900	408
JBFA 099E	38	965	60 1/16	1526	1 3/8	2 1/8	1000	454
JBFA 114E	38	965	60 1/16	1526	1 3/8	2 1/8	1100	499
JBFA 122E	50	1270	40 1/16	1018	1 3/8	2 1/8	1225	556
JBFA 142E	50	1270	40 1/16	1018	1 3/8	2 1/8	1305	592
JBFA 163E	50	1270	40 1/16	1018	1 3/8	2 1/8	1390	631
JBFA 063E	38	965	60 1/16	1526	1 3/8	2 1/8	830	376
JBFA 078E	38	965	60 1/16	1526	1 3/8	2 1/8	900	408
JBFA 092E	38	965	60 1/16	1526	1 3/8	2 1/8	1000	454
JBFA 108E	38	965	60 1/16	1526	1 3/8	2 1/8	1100	499
JBFA 111E	50	1270	40 1/16	1018	1 3/8	2 1/8	1225	556
JBFA 132E	50	1270	40 1/16	1018	1 3/8	2 1/8	1305	592
JBFA 153E	50	1270	40 1/16	1018	1 3/8	2 1/8	1390	631

(1) O.D. in inches

HOT GAS DEFROST DIMENSIONS AND WEIGHTS

Electrical Service Entrance Size		
	2 Fan Models	3 Fan Models
Motors - A	7/8" (22) Dia.	1-23/32" (44) Dia.
Controls - B	7/8" (22) Dia.	1-23/32" (44) Dia.

REVERSE CYCLE DEFROST MODEL

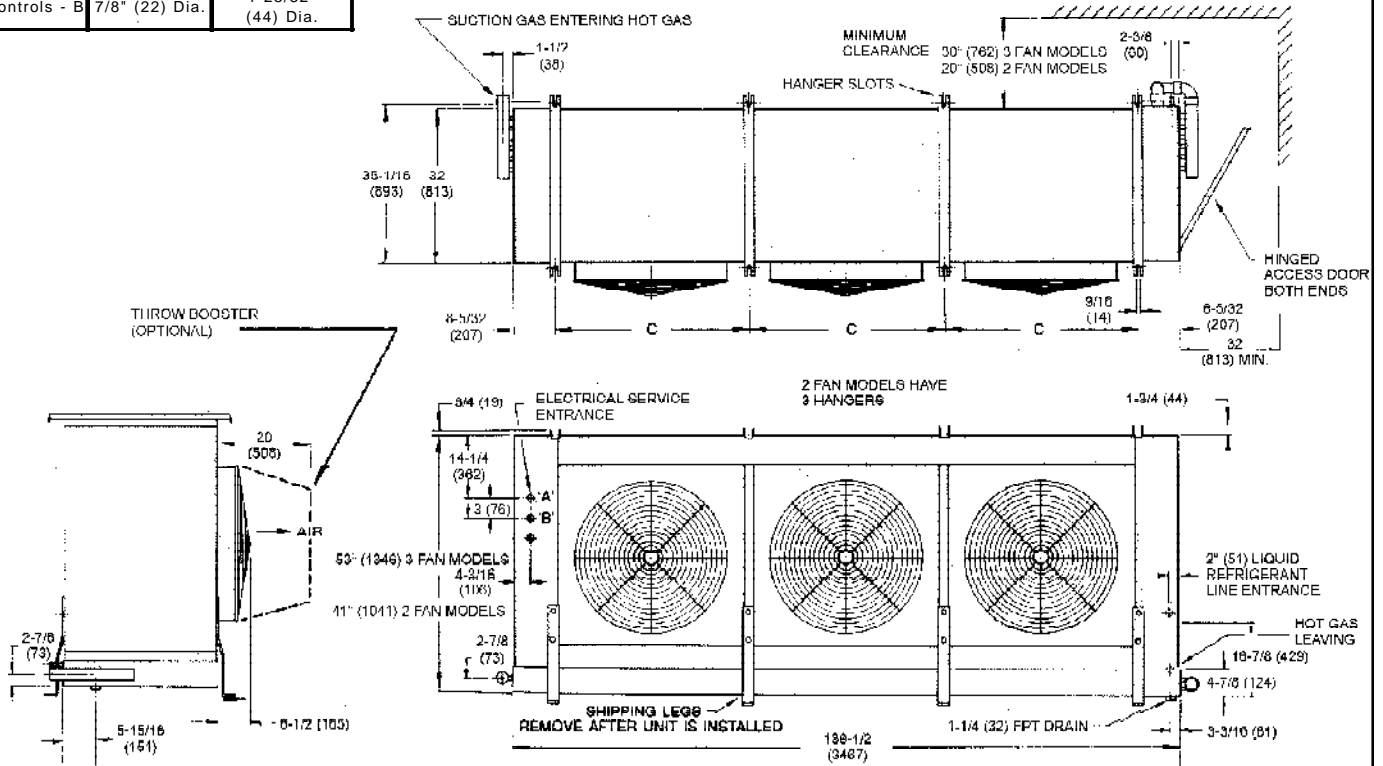

All Dimensions (mm)

HOT GAS DEFROST MODEL	HEIGHT		HANGERS		REFRIGERANT CONNECTIONS (1)		HOT GAS CONNECTIONS				UNIT WEIGHT	
	Inches	mm	C		LIQUID R404A, R-22,R-502	SUCTION R404A, R-22,R-502	3-PIPE		REVERSE		Lb.	kg
			Inches	mm			ENT.	LVG.	ENT.	LVG.		
JBFA 075 H/R	41	1041	60 1/16	1526	1 3/8	2 1/8	1 3/8	2 1/8	2 1/8	1 3/8	830	376
JBFA 090 H/R	41	1041	60 1/16	1526	1 3/8	2 1/8	1 3/8	2 1/8	2 1/8	1 3/8	900	408
JBFA 105 H/R	41	1041	60 1/16	1526	1 3/8	2 1/8	1 3/8	2 1/8	2 1/8	1 3/8	1000	454
JBFA 120 H/R	41	1041	60 1/16	1526	1 3/8	2 1/8	1 3/8	2 1/8	2 1/8	1 3/8	1100	499
JBFA 130 H/R	53	1346	40 1/16	1018	1 3/8	2 1/8	1 5/8	2 5/8	2 5/8	1 5/8	1225	556
JBFA 150 H/R	53	1346	40 1/16	1018	1 3/8	2 1/8	1 5/8	2 5/8	2 5/8	1 5/8	1305	592
JBFA 170 H/R	53	1346	40 1/16	1018	1 3/8	2 1/8	1 5/8	2 5/8	2 5/8	1 5/8	1390	631
JBFA 069 H/R	41	1041	60 1/16	1526	1 3/8	2 1/8	1 3/8	2 1/8	2 1/8	1 3/8	830	376
JBFA 084 H/R	41	1041	60 1/16	1526	1 3/8	2 1/8	1 3/8	2 1/8	2 1/8	1 3/8	900	408
JBFA 099 H/R	41	1041	60 1/16	1526	1 3/8	2 1/8	1 3/8	2 1/8	2 1/8	1 3/8	1000	454
JBFA 114 H/R	41	1041	60 1/16	1526	1 3/8	2 1/8	1 3/8	2 1/8	2 1/8	1 3/8	1100	499
JBFA 122 H/R	53	1346	40 1/16	1018	1 3/8	2 1/8	1 5/8	2 5/8	2 5/8	1 5/8	1225	556
JBFA 142 H/R	53	1346	40 1/16	1018	1 3/8	2 1/8	1 5/8	2 5/8	2 5/8	1 5/8	1305	592
JBFA 163 H/R	53	1346	40 1/16	1018	1 3/8	2 1/8	1 5/8	2 5/8	2 5/8	1 5/8	1390	631
JBFA 063 H/R	41	1041	60 1/16	1526	1 3/8	2 1/8	1 3/8	2 1/8	2 1/8	1 3/8	830	376
JBFA 078 H/R	41	1041	60 1/16	1526	1 3/8	2 1/8	1 3/8	2 1/8	2 1/8	1 3/8	900	408
JBFA 092 H/R	41	1041	60 1/16	1526	1 3/8	2 1/8	1 3/8	2 1/8	2 1/8	1 3/8	1000	454
JBFA 108 H/R	41	1041	60 1/16	1526	1 3/8	2 1/8	1 3/8	2 1/8	2 1/8	1 3/8	1100	499
JBFA 111 H/R	53	1346	40 1/16	1018	1 3/8	2 1/8	1 5/8	2 5/8	2 5/8	1 5/8	1225	556
JBFA 132 H/R	53	1346	40 1/16	1018	1 3/8	2 1/8	1 5/8	2 5/8	2 5/8	1 5/8	1305	592
JBFA 153 H/R	53	1346	40 1/16	1018	1 3/8	2 1/8	1 5/8	2 5/8	2 5/8	1 5/8	1390	631

(1) O.D. in inches

HOT GAS DEFROST DIMENSIONS AND WEIGHTS

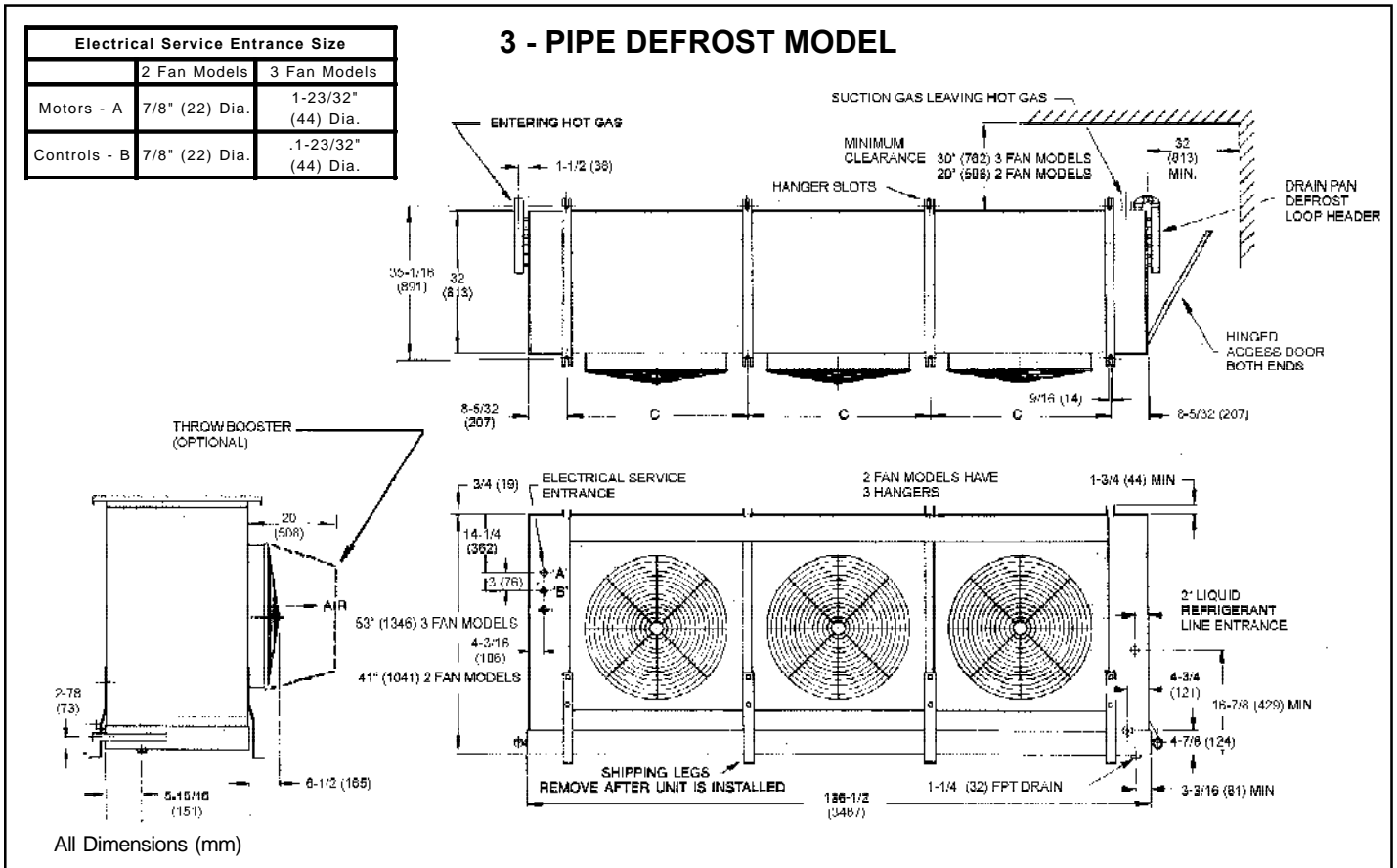

INSTALLATION INSTRUCTIONS

INSPECTION

Careful inspection of all parts when received for loss or damage in transit is very important - Remember, you, the consignee, must make any claim necessary against the transportation company. Shipping damage or missing parts, when discovered at the outset, will prevent later unnecessary and costly delays.

Ensure that the electrical characteristics are as ordered. Save all tags and instruction sheets for reference by installer and owner.

LOCATION

The unit location in the room should be selected to ensure uniform air distribution throughout the entire space to be refrigerated. Make sure that the fan does not blow directly out or pull in through an opened door and that the product does not obstruct the free circulation of air.

When installing the unit adjacent to a wall, sufficient clearance must be provided to allow free air movement to the coil.

Clearance must be provided at each end of the unit to

allow access to refrigerant piping and electrical compartment.

See dimensional drawings for clearance requirements.

INSTALLATION

Note: These units draw air through the coil and discharge air from the fan side

JBF Blast Freezers are supplied with shipping legs to allow units to be shipped in an upright position. Units are lifted into place with shipping skid attached to mounting legs.

Slotted hanger brackets take 1/2" (12.7mm) hanger rods. For fast, convenient mounting, install washer and nuts on hanger rods prior to lifting units. Rods may be lifted into slots and are held securely in place by tangs on hangers

After unit coolers are hung in place, remove shipping legs from units by removing the two 5/16" (8mm) bolts from each shipping leg.

Note: Shipping legs must be removed to allow hinged drain pan to open.

INSTALLATION INSTRUCTIONS

DRAIN LINE

If unit cooler is mounted flush to ceiling, the staggered high hanger will provide a positive pitch for drainage of condensate and defrost melt water.

If units are suspended below the ceiling, the installer should provide adequate pitch to the unit by adjusting the location of the hanger rod nuts.

Note: Check for adequate drainage by pouring water into the drain pan.

Insulated copper tube should be run from the drain connection, sloping at least 4" (102mm) per foot. A trap outside of the room will prevent warm air entering through the tubing. Connection should be made to proper drainage facilities that comply with local regulations.

It is necessary to heat the drain line to prevent condensate from freezing in the drain line. Electric heating cable or electric tape (by others) is used for this purpose. The drain line heater should be connected for continuous operation; it is also recommended that the drain line be insulated. A heat output of 20 watts per lineal foot of 1" (25mm) drain line in a 0°F (-18 °C) room is usually satisfactory. 115 volt cable and tape is available from your local refrigeration wholesaler. Two 115 volts heaters (by others) of the same wattage may be wired for use on 230 volt system

ELECTRICAL

Wire system in accordance with governing standards and local codes. See wiring diagrams for unit cooler wiring diagram and typical system wiring schematic.

Note: Electrical wiring is to be sized in accordance with minimum ampacity rating.

The defrost termination thermostats, fan delay thermostats and defrost heater safety thermostat are factory supplied and factory wired to a terminal block. See component identification diagram on wiring diagram for electrical compartment arrangement.

A hinged end panel provides quick access to the electrical compartment.

AFTER START UP

1. Check the oil level to be sure the oil charge is correct.
2. On the initial start up, the fans do not start until coil temperature is pulled down to approximately 26 °F (-3 °C)
Also, it is normal for the fans to cycle a few times until the room temperature is pulled down.
3. Make sure that the expansion valve is properly set so that the coil frosts evenly all the way through.
4. Heavy moisture loads are usually encountered when starting the system for the first time. This will cause a rapid build-up of frost on the unit cooler. During the initial pull down, we suggest that the frost build-up be watched and defrosted manually as required.

MAINTENANCE

1. Periodic checking and cleaning of the coil surface when necessary should be done, using a whisk or brush. Drain pans are hinged to provide convenient access to the inside coil surface.
2. Motors are permanently lubricated type and require no further lubrication.

REFRIGERATION SYSTEM

Refrigerant line sizes are important and should be the same size as the coil connections, or larger, depending on the length of run. Consult recommended refrigerant line sizes charts (KeepRite Refrigeration Engineering Manual or other recognized sources of information) when sizing refrigerant lines.

Refrigerant piping and control systems should be designed to prevent possible liquid slugging of the compressors on start-up after the defrost cycle.

Select an externally equalized expansion valve best suited to the coil and the application on the basis of the manufacturer's ratings. Install the expansion valve in the refrigeration piping compartment.

A 1/4" (6mm) O.D. equalizer line has been provided for the externally equalized expansion valve connection.

A Schrader valve fitting is supplied at the suction gas header to provide convenient pressure readings.

The refrigerant distributor is sized and installed at the factory and is supplied with a factory sized nozzle.

A hinged end panel provides quick access to the refrigeration piping compartment.

SYSTEM CHECK

1. All wiring should be in accordance with local codes.

2. All refrigerant lines should be properly sized and checked for any possible leaks.

3. Be sure system is charged with the proper refrigerant.

4. Make sure that the expansion valve thermal bulb is securely strapped to the suction line.

5. The system should include a liquid line drier and strainer.

6. The suction, discharge and receiver service valves must be open.

7. Check that the fans turn freely and turn in clock wise rotation.

8. Pour enough water into the drain pan to allow a good check on drainage and seal the trap.

ELECTRIC DEFROST MODELS

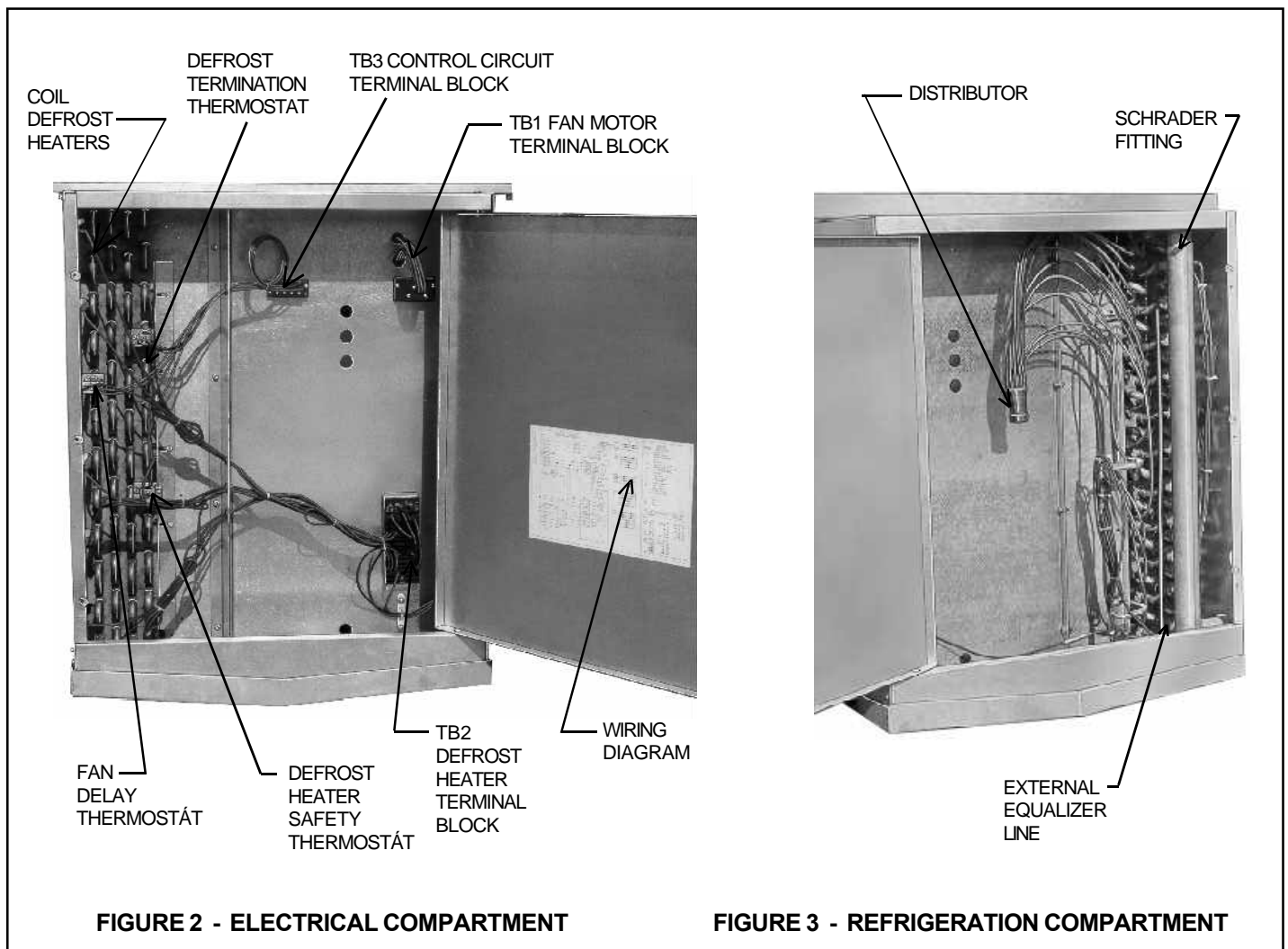
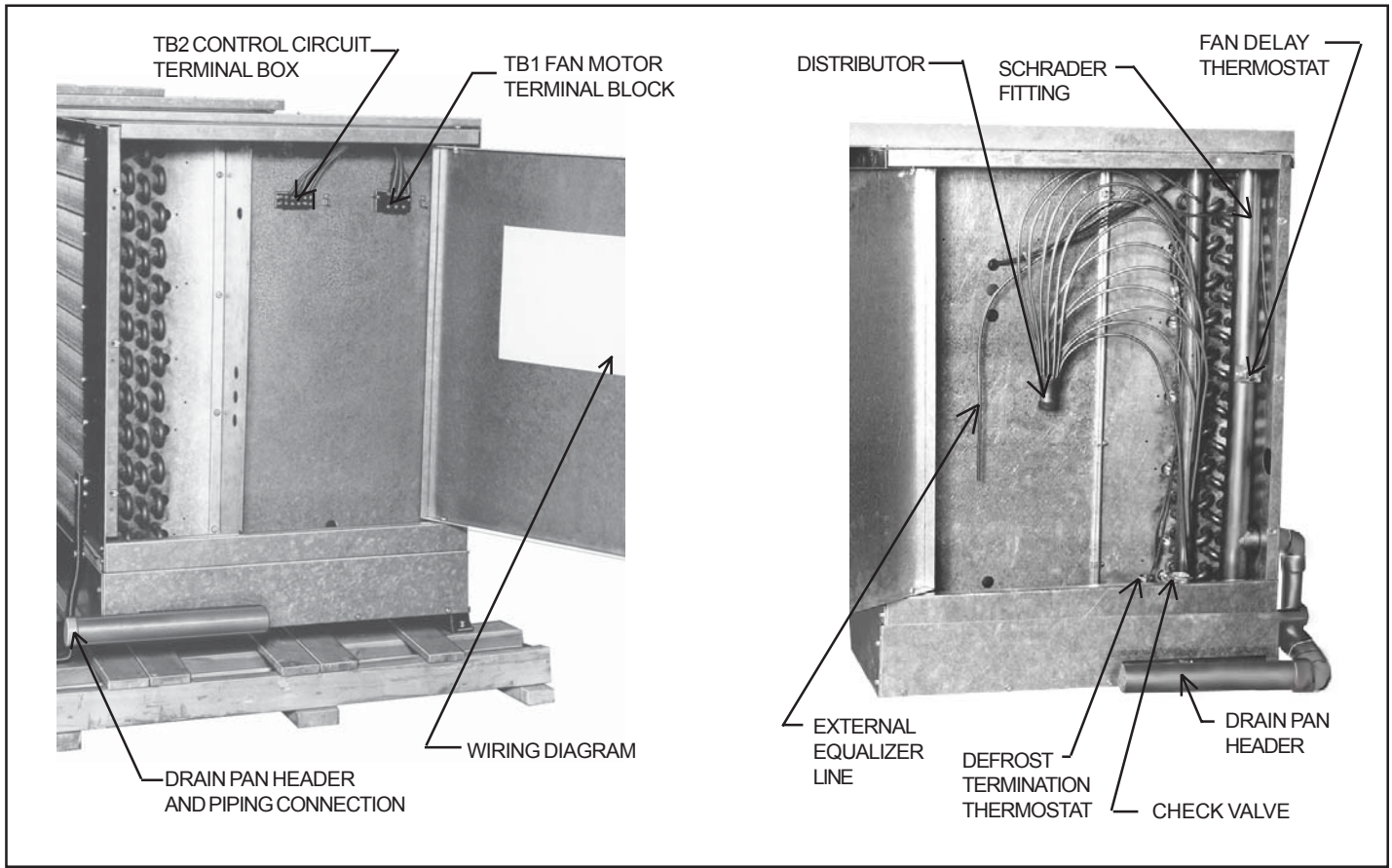

FIGURE 2 - ELECTRICAL COMPARTMENT

FIGURE 3 - REFRIGERATION COMPARTMENT

HOT GAS DEFROST MODELS



SERVICE PARTS LIST

FAN MOTORS	PART NUMBER
3 HP TEFC 208-230/3/60	1040346
3 HP TEFC 460/3/60	1040347
3 HP TEFC 575/3/60	1040348
FAN BLADE 30"	1040321
FAN MOTOR TERMINAL BLOCK TB1	1040160
DEFROST CONTROL TERMINAL BLOCK TB2	1040161
DEFROST HEATER TERMINAL BLOCK TB3	1040162
FAN DELAY THERMOSTAT	1040240
DEFROST TERMINATION THERMOSTAT	1040239
COIL DEFROST HEATERS	
208-230/3/60	1040167
460/3/60	1040166
575/3/60	1040165
DRAIN PAN DEFROST HEATERS	
208-230/3/60	1040167
460/3/60	1040166
575/3/60	1040165
THROW BOOSTER	1041036

PROJECT INFORMATION

System	
Model Number	Date of Start-Up
Serial Number	Service Contractor
Refrigerant	Phone
Electrical Supply	Fax



NATIONAL REFRIGERATION & AIR CONDITIONING CANADA CORP.
159 ROY BLVD., BRANTFORD, ONTARIO, CANADA N3R 7K1
PHONE: 1-800-463-9517 (519)751-0444 FAX (519)753-1140



Due to National Refrigeration's policy of continuous product improvement, we reserve the right to make changes without notice.