



HCU Hermetic Condensing Units

R22 - R404A

PRODUCT DATA & INSTALLATION

Bulletin K40-HCU-PDI-12

1068830

We are on the Internet  www.keepriterefrigeration.com

**Indoor Air Cooled 3/4 HP - 5 HP
For High, Medium and Low Temperature Applications**

**Electrical Power: 115/1/60, 208-230/1/60,
208-230/3/60**

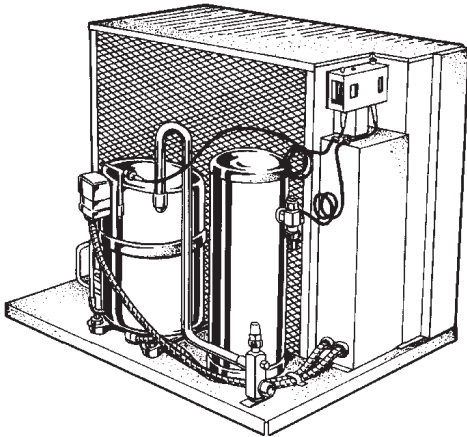

- UL and CSA approved.
- Economical welded hermetic compressors.
- High-efficiency fan motors for lower energy cost.
- Single, easily accessible electrical panel to speed installation and servicing.
- Up front service valves for fast access.
- Accepts standard off-the-shelf components for quick emergency repairs.
- Large receivers providing maximum pumpdown capability.
- Low pressure, dual pressure controls and contactors included (where required).
- Crankcase heaters included on all high temperature 1 1/2 HP through 5 HP models.

NOMENCLATURE

HCU A 100 H 2 A D D -K

INDOOR
HERMETIC
CONDENSING UNIT

SERIES/GENERATION
A = 1st GENERATION
B = 2nd (Using Tecumseh)

NOMINAL H.P. ÷ 100
E.G. 100 = 1HP

APPLICATION TEMP.
H = HIGH / MEDIUM, L = LOW

REFRIGERANT TYPE
2 = R22, 6 = R404A, R507

CONDENSING MEDIA
A = AIR COOLED

ELECTRICAL DESIGNATION
A = 115/1/60
D = 208-230/1/60
H = 208-230/3/60

BILL OF MATERIAL CODE
(For reference purpose only)

KEEPRITE

CONTENTS

PAGE

SPECIFICATIONS

Nomenclature.....	Cover
Capacity Data.....	2
General Specifications.....	2
Electrical Data.....	3
Wiring Diagrams.....	3, 4

INSTALLATION

General Information.....	5
Inspection.....	5
Site Survey.....	5
Ventilation.....	5
Electrical Information.....	5
Refrigerant Piping.....	6
Leak Testing.....	6
Evacuation and Dehydration.....	6
Dehydration Procedure.....	6
Refrigerant Charging.....	7
Oil.....	7
Low/High Pressure Controls.....	7
Final Check and Inspection.....	7
24 Hour Inspection.....	7
Customer Instructions.....	7
Service Parts.....	Back
Service Log.....	Back

CAPACITY DATA

**R22 HIGH/MEDIUM TEMPERATURE MODELS

BTU/HR (WATTS)

MODEL	EVAPORATING TEMPERATURE															
	°F		°C		°F		°C		°F		°C		°F		°C	
	+20	-6.7	+25	-3.9	+30	-1.1	+35	1.7	+40	4.4	+45	7.2	+50	10.0		
HCUA075H2A*-K	5500	(1610)	6200	(1815)	6900	(2020)	7600	(2225)	8400	(2460)	9100	(2664)	9800	(2869)		
HCUA100H2A*-K	7200	(2108)	8300	(2430)	9500	(2782)	10600	(3104)	11700	(3426)	13000	(3806)	14300	(4187)		
HCUA150H2A*-K	10300	(3016)	11900	(3484)	13300	(3894)	14800	(4333)	16300	(4773)	18000	(5270)	19600	(5739)		
HCUA200H2A*-K	14500	(4246)	16500	(4831)	18500	(5417)	20600	(6032)	22800	(6676)	25000	(7320)	27500	(8052)		
HCUA300H2A*-K	20500	(6002)	23200	(6793)	25900	(7584)	28800	(8433)	31700	(9282)	35000	(10248)	38100	(11156)		
HCUA350H2A*-K	24500	(7174)	27700	(8111)	30900	(9048)	34700	(10160)	38200	(11185)	42000	(12298)	46000	(13469)		
HCUA400H2A*-K	31100	(9106)	34800	(10189)	39100	(11448)	43400	(12708)	47600	(13937)	52000	(15226)	56700	(16602)		
HCUA500H2A*-K	36800	(10775)	41500	(12151)	46100	(13498)	50300	(14728)	55400	(16221)	60200	(17627)	64800	(18973)		

R404A LOW TEMPERATURE MODELS

BTU/HR (WATTS)

MODEL	EVAPORATING TEMPERATURE															
	°F		°C		°F		°C		°F		°C		°F		°C	
	-40	-40.0	-30	-34.4	-25	-31.7	-20	-28.9	-15	-26.1	-10	-23.3	0	-17.8		
HCUB100L6A*-K	1400	(410)	2340	(685)	2940	(861)	3540	(1037)	4170	(1221)	4840	(1417)	6200	(1815)		
HCUB150L6A*-K	2700	(791)	4560	(1335)	4050	(1186)	6650	(1947)	7800	(2284)	9040	(2647)	11220	(3285)		
HCUB200L6A*-K	4210	(1233)	6530	(1912)	7750	(2269)	8970	(2626)	10330	(3025)	11770	(3446)	14830	(4342)		
HCUB300L6A*-K	5340	(1564)	8280	(2424)	9840	(2881)	11400	(3338)	13140	(3847)	14970	(4383)	18890	(5531)		

*Insert electrical designation followed by bill of material code
 **Lower Evaporating temperature ranges (below+20F) available. Consult factory.
 All data rated at 90°F ambient, 90°F return gas for R22, 65°F return gas for R404A and 5°F subcooling.
 Increase capacity by approximately 6% for every 10°F of lower ambient temperature.
 Decrease capacity by approximately 6% for every 10°F ambient increase.

SPECIFICATIONS

REFRI-GERANT	APPLIC-ATION	HP	VOLTS	HCU MODEL	COMPRESSOR MODEL	DIMENSIONS INCHES (mm)			SUCTION VALVE	LIQUID VALVE	RECVR LBS (90%)	OIL CHARGE (OZ'S)	APPROX. UNIT WEIGHT LBS (Kg)
						BASE LENGTH	COND. WIDTH	OVERALL HEIGHT					
R22	HIGH	3/4	115-1	HCUA075H2AAE-K	RSE40075IAA	21-1/2 (546)	17-3/8 (439)	13-7/8 (353)	5/8RS	3/8F	7.6	22	92 (42)
R22	HIGH	3/4	208/230-1	HCUA075H2ADE-K	RSE40075IAV	21-1/2 (546)	17-3/8 (439)	13-7/8 (353)	5/8RS	3/8F	7.6	22	92 (42)
R22	HIGH	1	208/230-1	HCUA100H2ADD-K	H24B13QABCB	21-1/2 (546)	17-3/8 (439)	13-7/8 (353)	5/8BS	3/8F	7.6	40	102 (46)
R22	HIGH	1-1/2	208/230-1	HCUA150H2ADF-K	H23B193ABCA	24-7/8 (632)	19-1/2 (495)	16 (406)	5/8BS	3/8F	7.6	40	114 (52)
R22	HIGH	2	208/230-1	HCUA200H2ADF-K	H23B243ABCA	25 (635)	33-1/2 (851)	19-1/2 (495)	7/8BS	3/8F	14	50	141 (64)
R22	HIGH	3	208/230-1	HCUA300H2ADF-K	H23A353ABCA	25 (635)	33-1/2 (851)	19-1/2 (495)	7/8BS	1/2F	17.1	50	162 (73)
R22	HIGH	3-1/2	208/230-1	HCUA350H2ADH-K	H23A423ABCA	28-1/2 (724)	44-7/8 (1140)	26-1/2 (673)	7/8BS	1/2F	17.1	50	191 (87)
R22	HIGH	4	208/230-1	HCUA400H2ADH-K	H23A543ABCA	28-1/2 (724)	44-7/8 (1140)	26-1/2 (673)	7/8BS	1/2F	20	55	200 (91)
R22	HIGH	5	208/230-1	HCUA500H2ADH-K	H23A623ABCA	28-1/2 (724)	44-7/8 (1140)	26-1/2 (673)	7/8BS	1/2F	20	55	217 (98)
R22	HIGH	5	208/230-3	HCUA500H2AHH-K	H23A623DBLA	28-1/2 (724)	44-7/8 (1140)	26-1/2 (673)	7/8BS	1/2F	20	55	207 (94)
R404A	LOW	1	208/230-1	HCUB100L6ADE-K	AWA2440Z	21-1/2 (546)	17-3/8 (439)	14-1/2 (368)	5/8RS	3/8F	6.6	38	104 (47)
R404A	LOW	1	208/230-3	HCUB100L6AHG-K	AWA2440Z	21-1/2 (546)	17-3/8 (439)	14-1/2 (368)	5/8RS	3/8F	6.6	38	104 (47)
R404A	LOW	1-1/2	208/230-1	HCUB150L6ADG-K	AWA2460Z	25 (635)	33-1/2 (851)	19-1/2 (495)	7/8RS	3/8F	12	38	138 (63)
R404A	LOW	1-1/2	208/230-3	HCUB150L6AHG-K	AWA2460Z	25 (635)	33-1/2 (851)	19-1/2 (495)	7/8RS	3/8F	12	38	138 (63)
R404A	LOW	2	208/230-1	HCUB200L6ADH-K	AVA2490Z	25 (635)	33-1/2 (851)	19-1/2 (495)	7/8BS	3/8F	12	54	143 (65)
R404A	LOW	2	208/230-3	HCUB200L6AHH-K	AVA2490Z	25 (635)	33-1/2 (851)	19-1/2 (495)	7/8BS	3/8F	12	54	143 (65)
R404A	LOW	3	208/230-1	HCUB300L6ADH-K	AVA2512Z	25 (635)	33-1/2 (851)	19-1/2 (495)	1 1/8BS	1/2F	14.9	54	162 (73)
R404A	LOW	3	208/230-3	HCUB300L6AHH-K	AVA2512Z	25 (635)	33-1/2 (851)	19-1/2 (495)	1 1/8BS	1/2F	14.9	54	162 (73)

VALVE NOTES: F = FLARE, S = SWEAT, R = ROTALOCK, B = BASE MOUNTED

ELECTRICAL DATA

REFRIGERANT	APPLICATION	HP	VOLTS(60Hz)	HCU MODEL	COMPRESSOR		FAN FLA	MIN. CIRC. AMPACITY	MAXIMUM OVERCURRENT PROTECTION
					RLA	LRA			
R22	HIGH	3/4	115-1	HCUA075H2AAE-K	14.3	66.3	1.8	18.7	30
R22	HIGH	3/4	208/230-1	HCUA075H2ADE-K	7.2	35.5	.85	9.9	15
R22	HIGH	1	208/230-1	HCUA100H2ADD-K	8.7	42	.85	11.7	20
R22	HIGH	1-1/2	208/230-1	HCUA150H2ADF-K	10.3	57	.85	13.7	20
R22	HIGH	2	208/230-1	HCUA200H2ADF-K	12.9	66	2.2	18.3	30
R22	HIGH	3	208/230-1	HCUA300H2ADF-K	17.6	87	2.2	24.2	30
R22	HIGH	3-1/2	208/230-1	HCUA350H2ADH-K	20.0	110	2.2	27.2	40
R22	HIGH	4	208/230-1	HCUA400H2ADH-K	28.8	138	2.2	38.2	50
R22	HIGH	5	208/230-1	HCUA500H2ADH-K	30.1	178	2.2	39.8	50
R22	HIGH	5	208/230-3	HCUA500H2AHH-K	20.5	124	2.2	27.8	40
R404A	LOW	1	208/230-1	HCUB100L6ADE-K	8.7	73	.85	11.7	20
R404A	LOW	1	208/230-3	HCUB100L6AHG-K	4.9	40.5	.85	7	15
R404A	LOW	1-1/2	208/230-1	HCUB150L6ADG-K	12.6	86	2.2	18	30
R404A	LOW	1-1/2	208/230-3	HCUB150L6AHG-K	8.3	63.4	2.2	12.6	20
R404A	LOW	2	208/230-1	HCUB200L6ADH-K	16.2	106.6	2.2	22.5	30
R404A	LOW	2	208/230-3	HCUB200L6AHH-K	9.9	65.1	2.2	14.6	20
R404A	LOW	3	208/230-1	HCUB300L6ADH-K	20.8	120.3	2.2	28.2	40
R404A	LOW	3	208/230-3	HCUB300L6AHH-K	11	65.1	2.2	16	25

WIRING DIAGRAMS

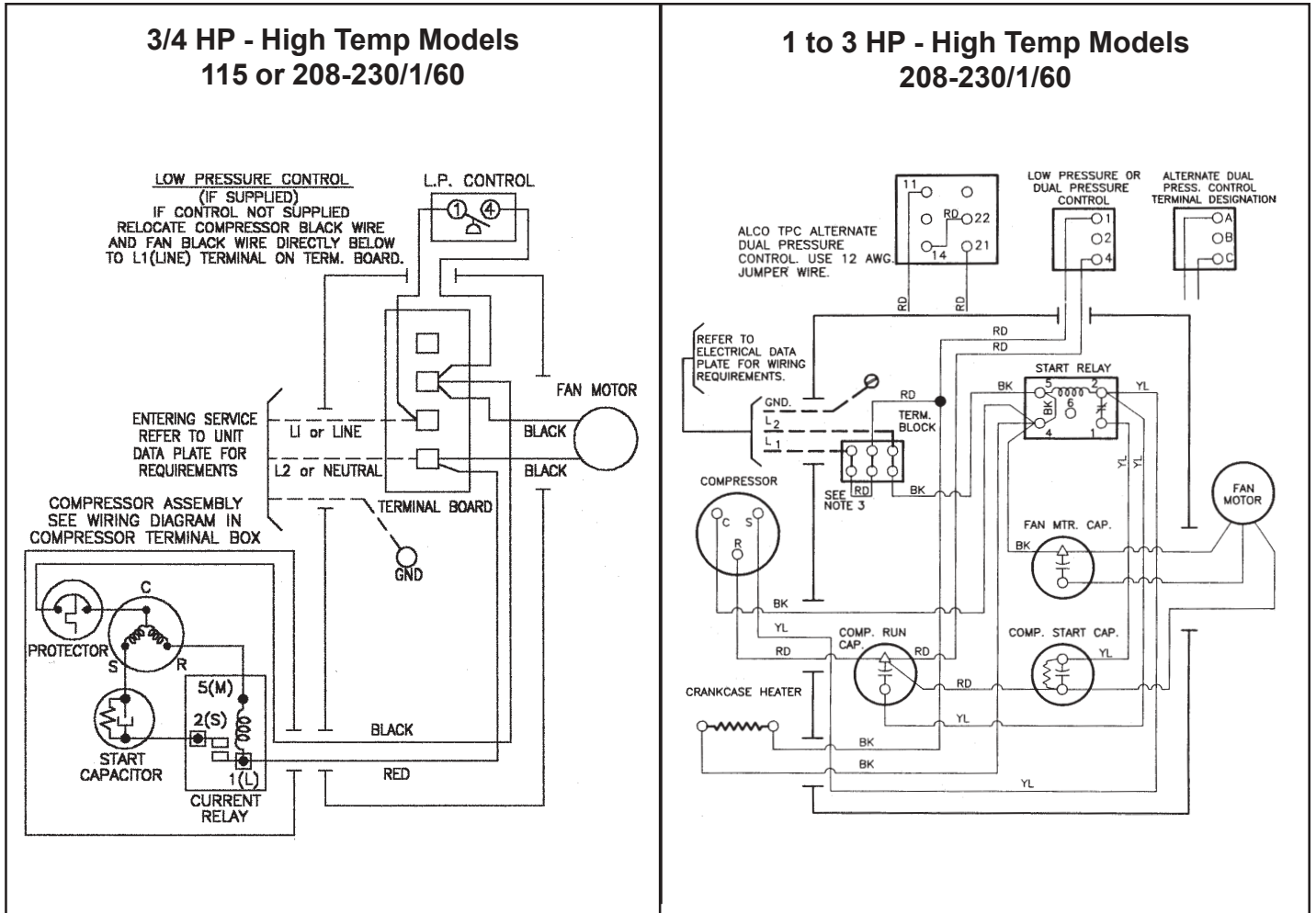

WIRING DIAGRAMS

3-1/2 to 5 HP - High Temp Models 208-230/1/60

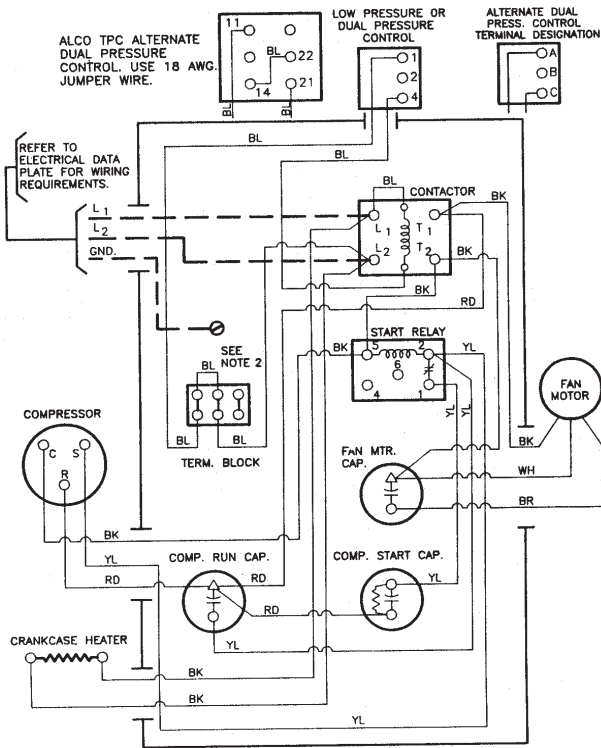

1 - 2 HP - Low Temp Models 208-230/1/60

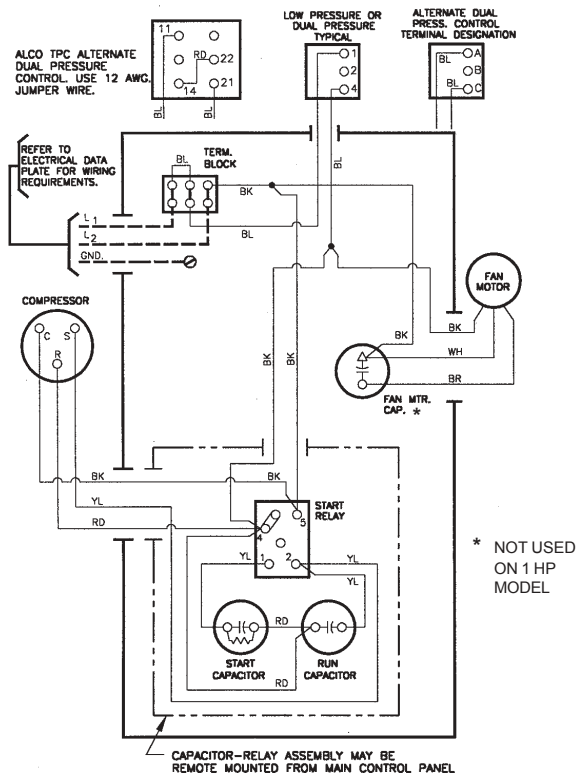

3 HP - Low Temp Model 208-230/1/60

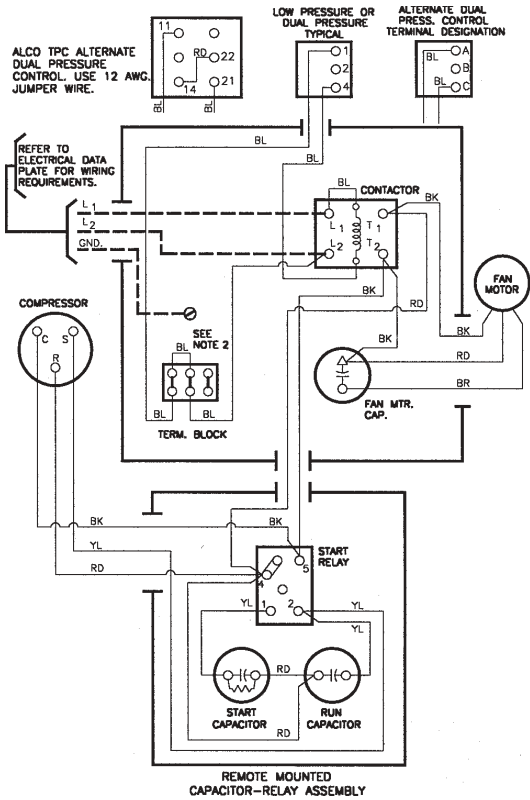

All 208-230/3/60 Models

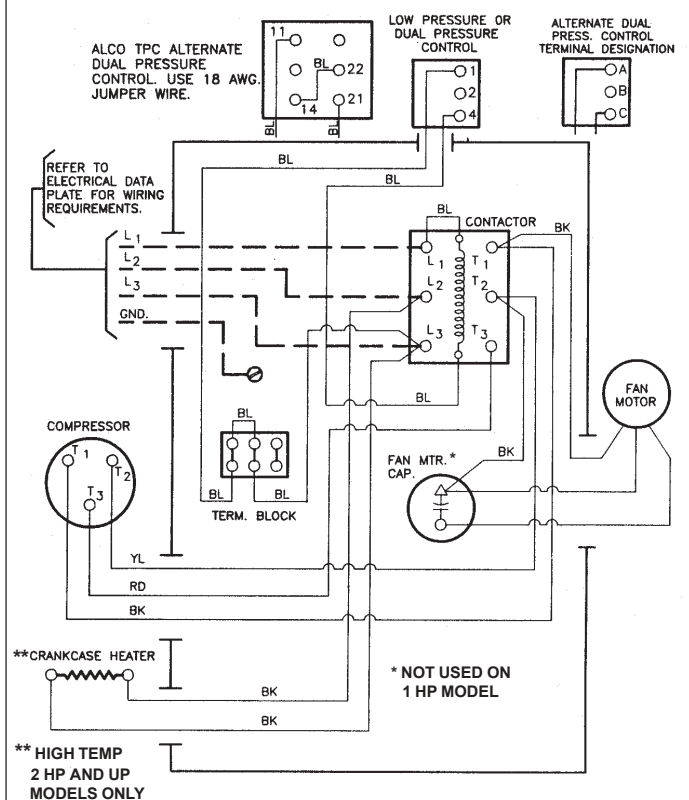

INSTALLATION INSTRUCTIONS

GENERAL

The installation and start-up on Hermetic Condensing Units should only be performed by qualified refrigeration mechanics. This equipment should be installed in accordance with all applicable codes, ordinances and local by-laws.

INSPECTION

Inspect all equipment before unpacking for visible signs of damage or loss. Check shipping list against material received to ensure shipment is complete.

IMPORTANT: Remember you, the consignee, must make any claim necessary against the transportation company. Shipping damage or missing parts, when discovered at the outset, will prevent later unnecessary and costly delays. **If damage or loss during transport is evident, make claim to carrier, as this will be their responsibility, not the manufacturer's.** Should carton be damaged, but damage to equipment is not obvious, a claim should be filed for "concealed damage" with the carrier.

IMPORTANT: The electrical characteristics of the unit should be checked at this time to make sure they correspond to those ordered and to electrical power available at the job site.

SITE SURVEY

Survey job site for location of equipment. Dimensions for this condensing unit will be found in the unit specifications. Allow **additional room** to these dimensions to perform any maintenance work. Place unit so that all service valves can be easily reached, and allow space for access to the control box. Install condensing unit in an area which will always be warmer than the refrigerated space. The unit should be placed on a level and even base where it will not be subjected to damage by traffic or flooding. Consideration in location should also be made for any objectional fan or compressor noise by personnel working close by.

VENTILATION

The equipment room should be adequately vented to dissipate heat from the compressor and condenser. Ventilation should provide make up supply air to the condenser and allow the same amount of discharge air from the room. Openings for supply air

should be equal to face area of the air cooled condenser or approximately 1 square foot of free opening per horsepower. Discharge opening should not be less than 1 square foot of free opening per horsepower of compressor. Units intended for operation in ambient temperatures below 40 °F (**4.4°C**) must be prepared by installer for winter operation.

ELECTRICAL INFORMATION

All wiring and connections to the unit must be made in accordance with all national as well as local electrical codes and by-laws. Electrical wiring should be sized in accordance with the minimum circuit ampacities shown on the unit nameplate and applicable electrical codes. The unit power connections are approved for copper wire only.

The maximum entering service fuse size is shown in the Electrical Data chart.

Field connected control circuit wires are terminated directly at the control circuit terminal block in accordance with the appropriate wiring diagram.

Voltage at unit terminals must not vary more than the allowable variation during start-up and while under full load. If the voltage is normal at the supply with the compressor not running and drops considerably when the switch is closed and the motor is trying to start. There is high resistance due to undersize wire or faulty connections. Voltage drop between inoperative and full load must not exceed 3% of line voltage. In addition, the phase imbalance at the motor terminals should be within 2% on three phase units.

POWER	ALLOWABLE VARIATION
115/1/60	103-127V
208-230/1/60	197-253V
208-230/3/60	187-253V

WARNING

Any deviation or change to the electrical components or wiring as supplied by manufacturer on the original equipment, or noncompliance with the voltage and phase balance requirements without written authorization will void the warranty.

INSTALLATION INSTRUCTIONS

REFRIGERANT PIPING

Proper piping practices should be used throughout the installation with particular attention to connection line sizing. Correct line sizing is important on all installations if efficient performance is to be obtained, and is of particular importance when the compressor unit is installed above the evaporator.

Piping practice and line sizing as recommended by A.S.H.R.A.E. or other reputable standards should be followed to insure minimum pressure drop and correct oil return. An inert gas such as nitrogen should be passed through the piping during all welding or brazing operations. This reduces or eliminates oxidation of the copper and formation of scale inside the piping.

Correct suction line sizing is most critical because of the several factors involved:

- (a) Minimum pressure drop to ensure efficient compressor performance.
- (b) Sufficient gas velocity to maintain oil return to the compressor under all load conditions.
- (c) Elimination of conditions on multiple evaporators whereby oil may log in an idle evaporator.

Suction lines should be sized on the basis of a maximum total pressure drop of 2 °F (**1.1°C**) change in saturated temperature. This is approximately 3 psig for R22 at high temperature +40 °F (**4.4°C**) and 1 1/2 psig for R404A at low temperature -10 °F (**-23.3°C**).

A certain amount of oil is always being pumped by the compressor. At the temperatures encountered in the condenser, receiver and liquid line, and with the refrigerant in liquid form the oil mixes with the refrigerant. However, at the evaporator temperature, and with the refrigerant in a vapour state the oil and refrigerant separate and the oil can only be returned to the compressor by gravity or by entrainment in the suction gas. Above evaporator installations leave no alternative but by entrainment so suction gas velocity and correct line sizing to maintain this velocity are imperative. Care must be taken not to oversize the suction line in the desire for maximum performance.

Gas velocity in vertical suction lines must not be less than 1,000 fpm (5.08 m/sec) (preferably 1,250 fpm to 1,500 fpm) (6.35 m/sec to 7.62 m/sec)).

All local codes should be observed in the installation of refrigerant piping. Piping accessories must include moisture indicating liquid sight glass and

a liquid line strainer drier, and should also include a suction line filter and liquid line solenoid. When welding service valves, always wrap valve with a damp cloth to prevent damage from heat.

LEAK TESTING

All system piping including the condensing unit and accessories should be thoroughly tested for leaks prior to start up and charging.

EVACUATION AND DEHYDRATION

When the system is free of refrigerant leaks, an evacuation of the entire system should be completed by using a "high vacuum" pump.

This evacuation, if completed correctly, will ensure long life for the system, elimination of moisture and non-condensable gas problems. Moisture problems causing compressor failure will void warrant. Follow recommended procedure carefully.

DEHYDRATION PROCEDURE

Use only a "high vacuum" pump capable of drawing a vacuum of 100 microns. Gauges or vacuum measuring instruments should be suitable to measure conditions at any stage of the process in order to give the operator indications of progress. For specific recommendations for these instruments refer to vacuum pump supplier.

Connecting jumper lines should be used to interconnect both high and low pressure side of the system. These lines should be at least 3/8" O.D. in order to handle light density vapour at high vacuum obtained at completion of operation. Lines smaller than this will slow down the process considerably as well as making final system vacuum questionable. The entire system temperature should be over 60°F (**15.5°C**) for evacuation to be effective. If the temperature is less than 60°F (**15.5°C**) the final vacuum should be 50 microns. Double evacuation with a "sweeping" of dry nitrogen is recommended. First evacuation should be to at least 250 micron depth. When this point is reached, break the vacuum with dry nitrogen to melt any moisture which may have frozen during the high vacuum stage. Discharge any pressure from system and re-evacuate to a final vacuum of a least 100 microns with 60°F (**15.5°C**) system temperature. With this calibre of evacuation, all moisture and non-condensables will be removed from the entire system.

INSTALLATION INSTRUCTIONS

REFRIGERANT CHARGING

Refrigerant may be added at the compressor through the compressor suction service valve **in gas form only**. Liquid charging must be done in the high side only.

As all units are shipped with only a dry gas holding charge they must be fully charged with refrigerant for which they were designed. The type of refrigerant to be used is specified on the name plate of the unit. When charging a unit you must use a clean and dry refrigerant. This is especially important when charging a low temperature system.

Observe system operating pressures during charging process as well as monitoring the liquid sight glass. Do not overcharge with refrigerant. Bubbles in a liquid sight glass may also indicate a restriction and not necessarily an undercharge.

OIL

Welded hermetic compressors normally do not have sight glasses or means of determining their oil level. This type of compressor is usually installed in packages or in close proximity to the fixture.

All compressors are factory charged with enough oil to compensate for any piping losses up to about 35 feet, (one way) remote location. In the event of any substantial oil loss due to a leak or excessive line run, we suggest recharging with the following oil (or approved equivalent):

3/4 to 5 HP High Temp Units.....Suniso 3GS
1 to 3 HP Low Temp Units.....Mobil EAL ARCTIC 32

Add approximately 1/3 oz per foot (one way) for any remote location over 35'. If in doubt of an actual oil level the only positive check is to remove the compressor and drain the oil (through the suction connection) and re-charge with the correct factory oil charge. (Refer to unit specifications). Do **NOT** re-use drained oil or oil that has been exposed to the atmosphere. Do **NOT** re-fill, at any one time, more than 110% of the compressor's factory specified charge. Allow time for some of the oil to circulate into the system. (Excessive oil in the compressor can result in excessive compressor noise, higher power consumption or internal compressor damage).

LOW AND HIGH PRESSURE CONTROLS (WHERE APPLICABLE)

The factory supplied low pressure control is **NOT** factory set and must be adjusted accurately to suit the application requirements.

The high pressure cut-out settings are factory set at 370 psig.

The control is also factory set for manual re-set (not automatic). If the above settings are not desired or suitable for the application a lower pressure adjustment charge or manual re-set override may be performed.

FINAL CHECK AND INSPECTION

A final check and inspection of the system should be made before leaving the job site.

- | | CHECK |
|---|--------------------------|
| 1. All tags, instruction sheets, etc., have been placed in a safe, accessible location. | <input type="checkbox"/> |
| 2. All piping, tubing, etc., has been checked and is vibration free. | <input type="checkbox"/> |
| 3. All shut-off valves are back-seated, packing glands have been tightened and caps replaced and tightened. | <input type="checkbox"/> |
| 4. Complete system has been leak tested. | <input type="checkbox"/> |
| 5. Refrigerant charge has been checked (clear liquid in sight glass). | <input type="checkbox"/> |
| 6. Operating voltage has been checked at motor terminals and is within allowable variation. | <input type="checkbox"/> |
| 7. All electrical connections have been tightened, and electric box covers replaced. | <input type="checkbox"/> |
| 8. Fans have been checked for correct rotation with no obstructions. | <input type="checkbox"/> |

24 HOUR INSPECTION

After system has been operating for 24 hours, recheck refrigerant charge and correct if necessary. Recheck electrical connections for tightness and perform a visual inspection for any other abnormal operating conditions.

CUSTOMER INSTRUCTIONS

Fill in Equipment and System Information on back cover of this Manual and provide a copy for the customer's reference.

Give customer instructions on normal operation of the system. Explain electrical switch operation as well as pointing out safety precautions. Advise on keeping equipment area clean and free of debris. If system has operational features, point these out to the operator.

SERVICE PARTS LIST

**Service Parts List
Label
To Be Attached
*HERE***

SERVICE LOG

DATE	COMMENTS



NATIONAL REFRIGERATION & AIR CONDITIONING CANADA CORP.
159 ROY BLVD., BRANTFORD, ONTARIO, CANADA N3T 5Y6
PHONE: 1-800-463-9517 (519)751-0444 FAX (519)753-1140

MEA



Due to National Refrigeration's policy of continuous product improvement, we reserve the right to make changes without notice.